

# A NEW EXTENSION OF DYNAMIC SIMPLEX MODEL FOR THE PUBLIC TRANSPORT CUSTOMER SATISFACTION

C. Bernini, A. Lubisco<sup>1</sup>

## 1. INTRODUCTION

In the last decades, the aim to reduce car traffic and the need of saving time and money to travel has yielded a rapid growth of urban public transportation. Travel companies and public administrations have shown an increasing interest in understanding what determines individual travel mode choices, which are the individual preferences and expectations about the urban transport and if all these factors change over time. In this context, the Customer Satisfaction analysis assumes a fundamental role in defining and programming business strategies, because it allows to analyze customer expectations and overall satisfaction and to evaluate the quality of services supplied by travel companies (Golob, 2003; Thøgersen, 2001; Cagnone *et al.*, 2003). The dynamic version of Customer Satisfaction analysis turns out to be particularly useful for monitoring both customer satisfaction over time and customer behaviour reaction to company strategies, and therefore for measuring their effectiveness and efficiency.

In this paper we address the following questions that are becoming increasingly important for public transport service managers: does the level of customer satisfaction change over time? If yes, which factors might explain these differences? Does customer expectation about the travel influence the overall satisfaction over time? In order to answer to these questions, we propose an extended dynamic version of LISREL model and we evaluate the performance of this extended model on an empirical data set obtained from a Customer Satisfaction Survey, that was carried out by the Faculty of Statistical Sciences for the TRAM Agency of public transport in Rimini in the period from 2000 to 2004.

Overall satisfaction is an abstract construct that summarizes customer experiences whit respect to consumption or purchase of products or services. In this sense it is not directly measurable and it can be interpreted as a latent variable (Steenkamp and Baumgartner, 2000). To model latent variable, we propose to use the Structural Equation Modelling approach and in particular the LISREL model (Jöreskog, 1970).

---

<sup>1</sup> All the work was discussed and agreed by both authors. Cristina Bernini wrote sections 1, 2, 4, 5 and 7; Alessandro Lubisco wrote sections 3 and 6.

LISREL allows to analyze the relationship between public transport overall satisfaction and its determinants because of it explicitly accounts for the measurement error when the latent variable of interest is represented by multiple manifest variables, such as the overall satisfaction of TRAM customers. This approach also allows to determine whether the hypothesized model gives an acceptable representation of the analyzed data. As regards dynamic Customer Satisfaction model, we propose an extended version of the traditional SIMPLEX Model (Jöreskog, 1970, 1979, 2001). The dynamic is introduced in the structural part of the model by supposing an AR(1) process for endogenous latent variables and by assuming that exogenous latent variables at time  $t$  affect endogenous latent variables at time  $t$ .

The dynamic analysis requires the use of panel data but unfortunately surveys repeated over time on the same customers are not usual. More frequently, the data are collected from Independent Repeated Surveys (IRS), in which different samples of customers from the same population are observed in several time occasions. The application of the *average cohort techniques* on IRS data leads to the so called *pseudo-panel*: the use of variables that do not change over time (for example the year of birth of the customers) let us both to define groups of homogenous individuals and to follow them as a panel (Deaton, 1985; Browning *et al.*, 1985). In this research, 65 cohorts of TRAM customers are considered and analysed with respect to their habits and evaluations towards public transport.

The work is developed in the following steps: firstly the theoretical framework for the analysis of the Customer Satisfaction in public transport is discussed, and the main hypotheses for the model specification are presented. Then data collection and some descriptive statistics are analysed. The average cohort technique and the specification of the dynamic LISREL model are presented in Section 4 and Section 5, respectively. In the last sections, model estimates, some economic results and future research developments are discussed.

## 2. THE CONCEPTUAL MODEL AND RESEARCH HYPOTHESES

The TRAM, the Public Transport Agency in Rimini (Italy), has been very interested in its own customer needs. Through Customer Satisfaction surveys, the Agency aims at evaluating the perceived quality of its public services in the province of Rimini, the level of customer satisfaction and loyalty and how these features change over time. The dynamic measure of the quality and the identification of the customer needs and expectations concur to evaluate the effectiveness of the Agency business strategies and to identify the customer requirements, such as modification of existing services or introduction of new services.

The aim is to analyse customer satisfaction over time in order to increase the public transport choice. In this context, the identification of the determinants influencing public transport mode choice becomes relevant. To this goal we propose a conceptual model which guides the following research. The model extends and integrates several research streams on public transport field. The first and simplest distinction between types of determinants influencing travel mode choices is between *external conditions* and *individual traveller characteristics*. Travel mode depends on

the availability of a public transport alternative for destination and time, on the locations of shops, jobs, and homes and on the transport infrastructure. Environment conditions, such as road construction and weather, have also been shown to influence the choice of travel mode. Among individual characteristics that influence travel mode choices there are age, gender, attitudes, income and habits (Jakobsson *et al.* 2002; Fujii *et al.* 2001; Gärling *et al.*; 2001). There is empirical evidence that the travel mode choice depends on individual age and there are also arguments that using public transport tends to become habitual. In particular, travel mode choice is dynamic: determinants are influenced by (past) behaviour. Thus habits are the result of performing the same behaviour frequently and in a stable context; behaviour may also lead to change in attitudes and in perceived control due to experience-based learning, self-inferences and cognitive dissonance.

Psychologists and marketing researchers also distinguish between *volitional* and *non-volitional determinants* of behaviour (Bagozzi and Warshaw 1990; Bagozzi 1994; Peter *et al.* 1999). External conditions are considered non-volitional, such as some of the individual characteristics (habits and individual characteristics). Another non-volitional individual characteristic that has been found to influence travel mode choices is the knowledge of public transport services such as routes, timetables, ticket price, and so on.

The focus in this paper is limited to determinants that have been found to have a fairly direct influence on public transport choice. Consistent with the outlined conceptual framework, the study is based on the assumption that public transport choices are partly volitional (influenced by the traveller satisfaction and expectation) and partly determined by non-volitional individual characteristics (transport services, habits, age, etc.). Therefore travel mode choices are based on some co-determinants: the traveller evaluation (about travel characteristics), personal abilities (expectations, habits) and individual characteristics (age).

In this framework, our conceptual model considers time travel evaluation, travel comfortableness evaluation, customer care evaluation, overall satisfaction and expectations on public transport services as separate constructs over time and over age (Figure 1). The proposed relationships among these constructs are presented in the following hypotheses:

- H.1. the greater the extent of satisfaction with time travel, the higher the level of overall satisfaction
- H.2. the greater the extent of satisfaction with comfortableness travel, the higher overall satisfaction
- H.3. the greater the extent of satisfaction with customer care, the higher the level of overall satisfaction
- H.4. the expectation on public transport services positively affects the overall satisfaction
- H.5.1 the overall satisfaction changes over time
- H.5.2 the influence of time travel, travel comfortableness, customer care and expectation on the overall satisfaction change over time
- H.6. the overall satisfaction changes with respect to age and therefore over life cycle.

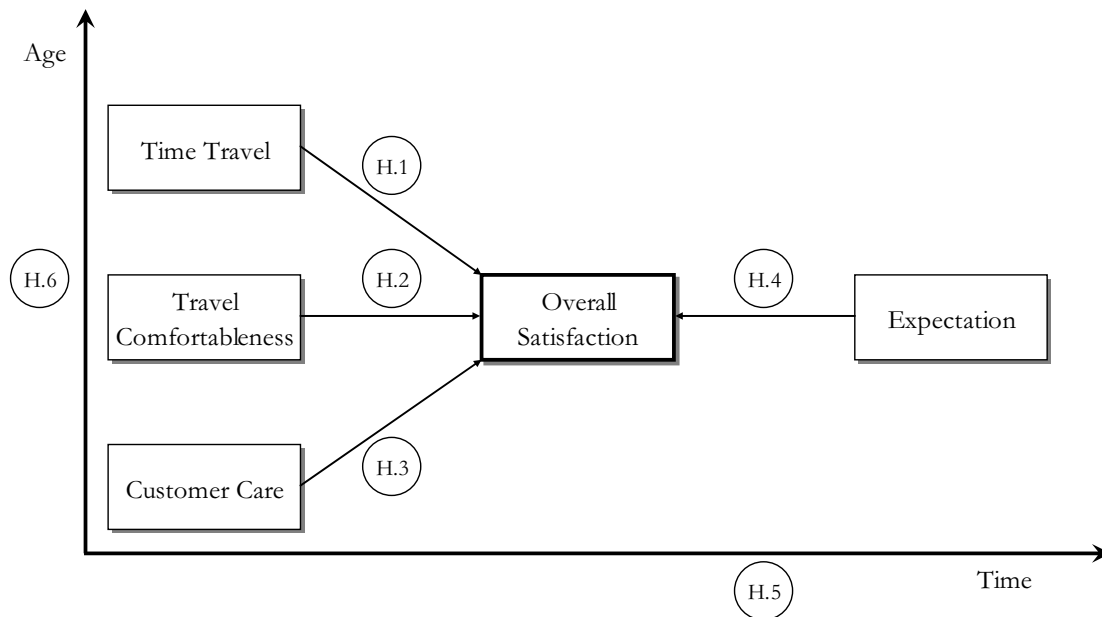

Figure 1 – Public transport conceptual model of Customer Satisfaction.

### 3. DATA

Since 1996 TRAM has been carrying out a biennial survey to evaluate habits and satisfaction of its customers. Since 2000 the Faculty of Statistical Sciences of the Bologna University has been involving in it, defining the sampling design, the questionnaire and the interview procedures. In the following, we present the main features of the survey.

#### 3.1. The data collection procedure

The population of interest consists of urban transport customers who choose the bus to move in the province of Rimini, for different reason. The sampling design is based on a stratification with respect to several characteristics of transport services (bus-routes, time bands, days) and service typology (urban, suburban).

One thousand questionnaires are administrated to customers, randomly chosen, by mean of a “face to face” technique on the bus during the trip. The surveys are conducted in the 2<sup>nd</sup> week of December.

#### 3.2. The questionnaire

The questionnaire is composed of four main sections: “Evaluations”, “Judgments”, “Habits” and “Personal data”.

The “Evaluations” section starts with a questions to pick out the most important reason of that particular trip. The main part of this section includes 15 items representing various aspects of the service, such as Bus frequency and speed, Travel comfort and safety, Information and Tickets availability, Ticket price, Ser-

vices for disabled people, Care of environment, Driver kindness. For each item, we asked people to give a score, expressed in terms of satisfaction and importance, using a Likert scale from 1 to 10. We also asked an evaluation of global satisfaction, always with a 1 to 10 scale.

In the “Judgment” section, all respondents were asked to give an evaluation on the expectation, in order to understand if the service was better, worse or equal to what they expected to have. Furthermore, people answered two questions to pick out the best and the worst aspect of the trip.

“Habits” section has the goal to observe the characteristics of TRAM customers for what concerns how and why they use the urban transport service to move. We asked which is the “usual” way the respondent uses to move, choosing between bus, car, motorcycle or bicycle, how many times per week he “usually” takes the bus, which kind of ticket he owns and where he buys it. In this section, the most important question concerns the principal reason for which they “usually” use the bus. This question helps us to distinguish between what we called “forced” and “unforced” customers.

In the “Personal data” section we collected information on age, gender, nationality, residence, educational degree and occupation. We asked also if the respondent had a driving licence.

### 3.3. Data description

Table 1 summarizes the variables used in our analysis, their operationalizations, and their mean values for the samples in 2000, 2002 and 2004 respectively. Table 1 also shows (in brackets) the standard deviations. The analysis of the Mean Satisfaction Index (MSI), calculated for each year as the average of the Satisfaction scores given by the respondents for all the 15 items, shows a progressive increase in the quality of the transport service aspects considered over time (Figure 2). In fact, the MSI passes from a scarcely sufficient value of 6.51 in year 2000, to values of 7.52 and 7.88 in 2002 and 2004, respectively. The positive trend is also confirmed by considering each item separately, where is evident that the average of the Satisfaction scores in 2004 are clearly higher than in 2000. Even better is the growth of the Global Satisfaction Index (GSI), calculated for each year as the average of the Global Satisfaction scores on all the respondents. The GSI passes from 5.89 in 2000, a level lower than the sufficiency threshold, to 8.06 and 8.39, respectively in 2002 and 2004.

Satisfaction indices show a positive trend in the global service quality supplied by the agency. Also Importance Indices turn out to change over time: customers have modified not only their level of satisfaction, but also the priorities given to the various aspects of the service, as we can see in the Impact Matrix.

The Impact Matrix is a tool that helps in understanding which items seem to be critical in affecting the overall satisfaction. The Impact Matrix is a scatter plot in which the two dimensions are Importance (axis of abscissas) and Satisfaction (axis of ordinates). The four quadrants of this Cartesian system are named “Success Area”, “Maintenance Area”, “Indifference Area” and “Improvement Area”.

Each item is placed at the coordinates corresponding to the average of its scores for Importance and Satisfaction. For example, an item placed in the “Success Area” has high average scores both for Importance and Satisfaction, while, if it is positioned in the “Indifference Area”, it has low levels for both the dimensions. The “Improvement Area” is intended as a critical one. The items in this area have high Importance but low Satisfaction, indicating that the actions to improve the quality must be concentrated especially on these aspects of the service.

TABLE 1  
*Items descriptions, mean values and standard errors (in brackets)*

<i>Item</i>	<i>Operationalization</i>	<i>2000</i>	<i>2002</i>	<i>2004</i>
Convenience	Bus-Routes and Stops Convenience	6.97 (1.43)	8.27 (1.21)	8.35 (0.76)
Punctuality	Bus Punctuality	6.67 (1.24)	6.83 (1.52)	7.69 (0.93)
Frequency	Bus Frequency	6.78 (1.30)	7.26 (1.36)	7.61 (1.05)
Speed	Transfer Speed	7.18 (1.03)	7.51 (1.20)	8.26 (0.81)
Cleanliness	Bus Cleanliness	6.32 (1.29)	8.04 (1.20)	7.96 (0.89)
Comfort	Travel Comfort: Seats, Crowding, Air-Conditioning,	6.01 (1.39)	7.95 (1.16)	8.01 (0.87)
Safety	Travellers Personal and Property Safety	6.96 (1.13)	8.41 (1.14)	8.23 (0.81)
Drivers	Drivers Kindness	7.49 (1.07)	8.82 (0.94)	8.33 (1.04)
Bus Shelters	Bus Shelters: Visibility, Comfort, Informations	4.95 (1.44)	6.42 (1.24)	7.48 (0.86)
Handicap	Services for Disabled People	4.51 (1.42)	6.55 (1.65)	6.52 (1.26)
Info	Information availability: Bus-Routes, Timetable, Prices	6.86 (1.38)	8.21 (1.22)	8.46 (0.94)
Ticket Price	Ticket Price	6.43 (1.51)	6.39 (1.27)	7.44 (1.13)
Customer Care	Customer Care: Complaints, Suggestions, Requests	6.94 (1.21)	6.18 (1.17)	7.57 (1.13)
Tickets Availability	Tickets Availability	7.76 (0.97)	8.69 (0.95)	8.85 (0.69)
Environment	Care of Environment: Ecological Vehicles, Air and Noise Pollution	5.90 (1.32)	7.31 (1.68)	7.38 (1.10)
Mean Satisfaction Index		6.51 (1.53)	7.52 (1.64)	7.88 (1.11)
Global Satisfaction Index		5.89 (0.81)	8.06 (1.11)	8.39 (0.73)

Figure 3 shows the positions of the items in 2002 (in bold) and 2004 (italic), linked by an arrow. It appears that almost all the arrows point towards the right side of the diagram, meaning that in 2004 the level of satisfaction increased for all the items, except for “Travellers Safety”, “Drivers kindness” and “Customer Care”. It appears, also, that the level of importance changed from 2002 to 2004. In fact, some items in 2004 are in a different “Area” with respect to 2002. “Ticket Availability” moved from the “Maintenance Area” to the “Success Area”, while

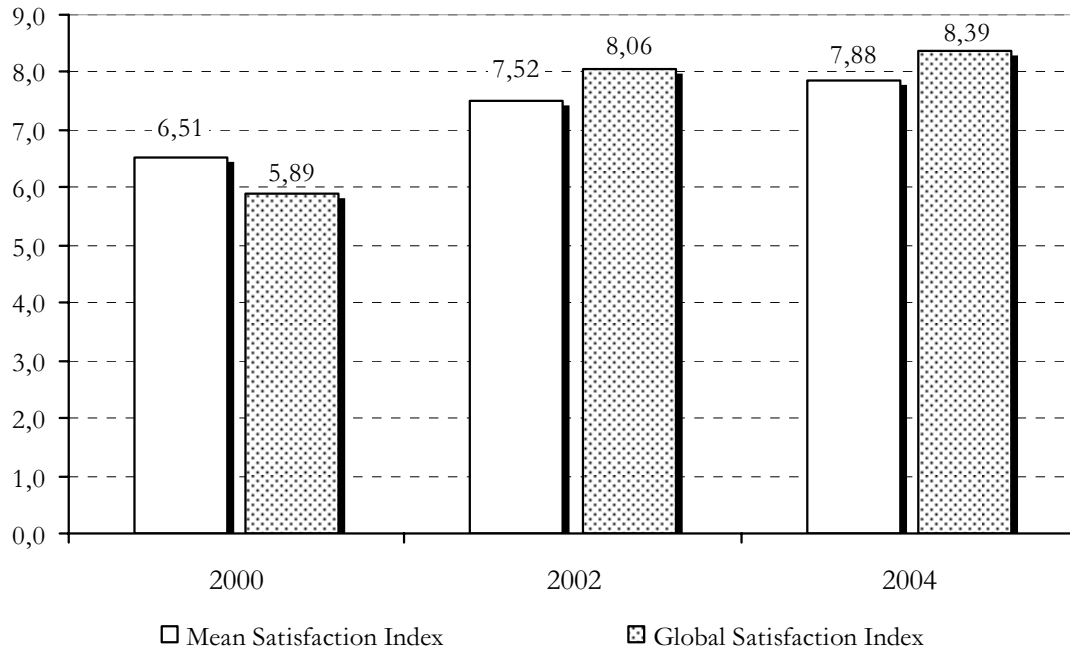

Figure 2 – The Mean Satisfaction Index and the Global Satisfaction Index (2000-2004).

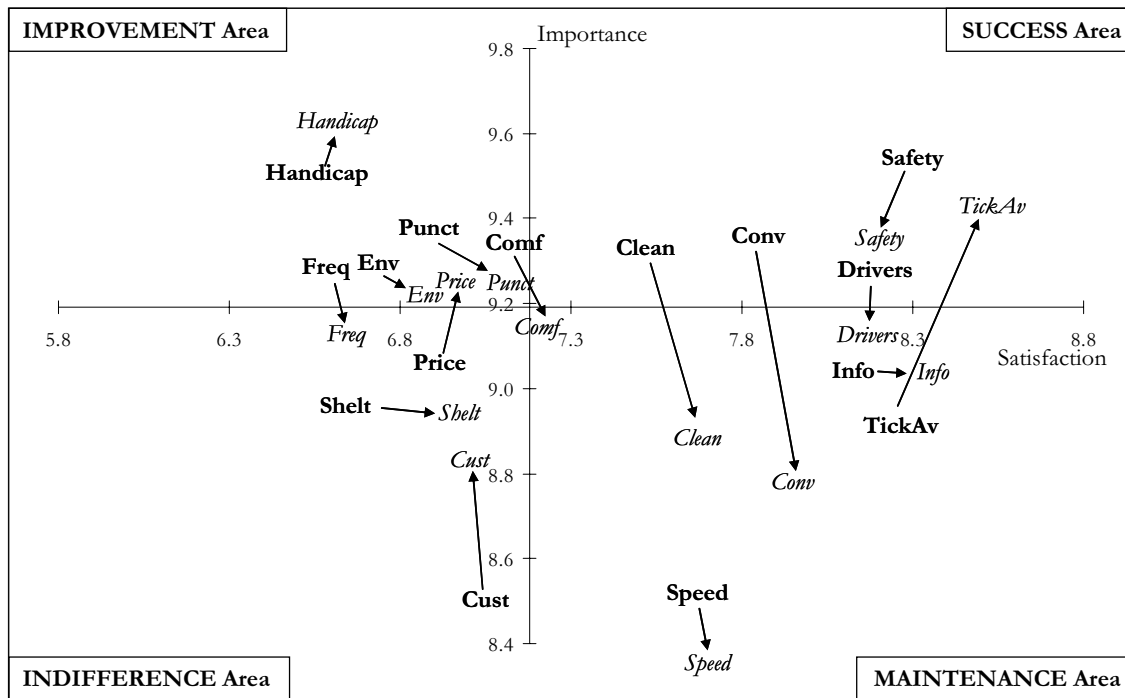

Figure 3 – The IMPACT MATRIX in 2002 (bold) and 2004 (italic).

“Bus Cleanliness”, “Bus-routes Convenience” and “Driver Kindness” covered the opposite way. “Ticket Price” becomes a critical aspect positioning itself in the “Improvement Area”: satisfaction for this item increased, but not enough to move it in the “Success Area”. Instead, the importance for the item “Bus Frequency” decreased letting it move from the “Improvement Area” to the “Indif-

ference Area". Also "Travel Comfort" moved away from the "Improvement Area" going in the "Maintenance Area" thanks to the growth of the level of satisfaction for this item together with the reduction of importance. "Travellers Safety" maintained its position in the "Success Area", as well as "Bus Shelters" and "Customer care" in the "Indifference Area" and "Services for Disabled People" together with "Care of Environment" and "Punctuality" in the "Improvement Area".

The Impact Matrix gives some preliminary indications about the changing in customer satisfaction over time. The interest is focused on the following questions: Which are the item dynamics? Which are the aspects of the service that determine the overall satisfaction dynamics? To answer to these questions we specify and estimate a dynamic version of the LISREL model on pseudo-panel data.

#### 4. DOES CUSTOMER SATISFACTION CHANGE OVER AGE?

Empirical evidence suggests that customer satisfaction changes with respect to customer age, and this represents an interesting feature in our analysis. In fact, if this is true, it is possible to use the economic framework of *life cycle* model and the statistical technique of *average cohort* to specify and estimate a dynamic model, overcoming the lack of panel data.

The average cohort technique, introduced by Deaton (1985) e Browning *et al.* (1985), has received a wide consent in theoretical and empirical economic literature. This technique finds its origin in the *life cycle model* (Modigliani and Brumberg, 1954) that uses the analysis of individual consumption behaviour to interpret aggregate consumption dynamics. The analysis of a single consumer behaviour over his life concurs to explore relations among preferences, decisions, socio-demographic characteristics and their changes in time.

Macroeconomic data for estimating and verifying microeconomic behavioural models are of common use in literature. Assumption guarantying the correct use of macroeconomic models instead of micromodels are generally based on the *representative agent hypothesis*. This hypothesis becomes unrealistic when used for phenomena, such as consumption or satisfaction, that vary among agents and over time. Data allowing to better analyse individual behaviours or preferences over life are time series of observations on the same individuals, as panel data. Customer surveys usually offer single cross-section surveys repeated in time. Hence in order to analyse customer satisfaction, it is necessary to assume that changes in time are represented by cross-section variations. This solution introduces restrictive hypotheses. Another methodologically correct solution exists. If time series of independent cross-section surveys (IRS) are available, it is possible to construct pseudo-panel data useful for estimating cohort behavioural models (Browning *et al.*, 1985; Deaton, 1985).

With IRS a customer is observed only at one occasion. However, independent customer samples, extracted from equivalent populations that have in common



one or more characteristics invariant in time, are available for successive surveys. Suppose the characteristic is the date of birth. In survey at time  $t$ , a subsample of customers of ages  $a$ , belonging to cohort  $c$ , is observed. In the year  $t+1$ , the procedure is repeated and customers of age  $a+1$  are observed; in the year  $t+2$ , customers of age  $a+2$ , always belonging to cohort  $c$ , are observed and so on for the following surveys. This technique allows to reproduce and observe customer quality evaluation following a cohort through its individuals. If subsamples are sufficiently large, sample means can be considered as representative of cohort individual behaviour. Hence, they can be analysed as if they were a panel. Average cohort technique allows the analysis of the behaviour of individuals having in common the year of birth, with respect to all satisfaction, economic and demographic variables.

This methodology proposed by Deaton uses, as cohort representative values, the mean values of each variable calculated on units belonging to the cohort for every time occasions. Repeating this procedure for all cohorts and linking these data, it is possible to reproduce satisfaction during customer life-cycle, as if we had panel data. Hence, cohort analysis allows to analyse age and cohort effects and to specify models useful for the analysis of individual behaviour over their life.

TRAM surveys are IRS and therefore they can be used to construct pseudo panel data and to estimate dynamic models of satisfaction by cohort average technique. Customers are grouped in 65 cohorts, defined with respect to their year of birth, excluded those born before 1920 and after 1984. Cohort representative values are the mean values of variables calculated on customers belonging to that cohort in each time period. Repeating for all the cohorts and linking them, satisfaction data over customer life-cycle are obtained. The use of a synthetic measure, such as the mean, for ordinal variables is largely discussed in the literature: the most commonly solution consists in treating measures in an ordinal scale as they were on an interval scale. This hypothesis is justified in presence of 10 scores (Zanella, 2001).

Average cohort technique allows to construct age satisfaction profiles, useful for analysing quality evaluation over customer age and time. Satisfaction has an increasing age profile: satisfaction grows slowly in initial phases of life-cycle and peaks its maximum value in correspondence to older age (Figure 4).

The analysis of the global satisfaction and the single item satisfaction shows that quality evaluation change over customer age and therefore the life cycle model and the average cohort technique can usefully used to explore the dynamics in the quality evaluation of the public transport by the Extended SIMPLEX model proposed in the next paragraph.

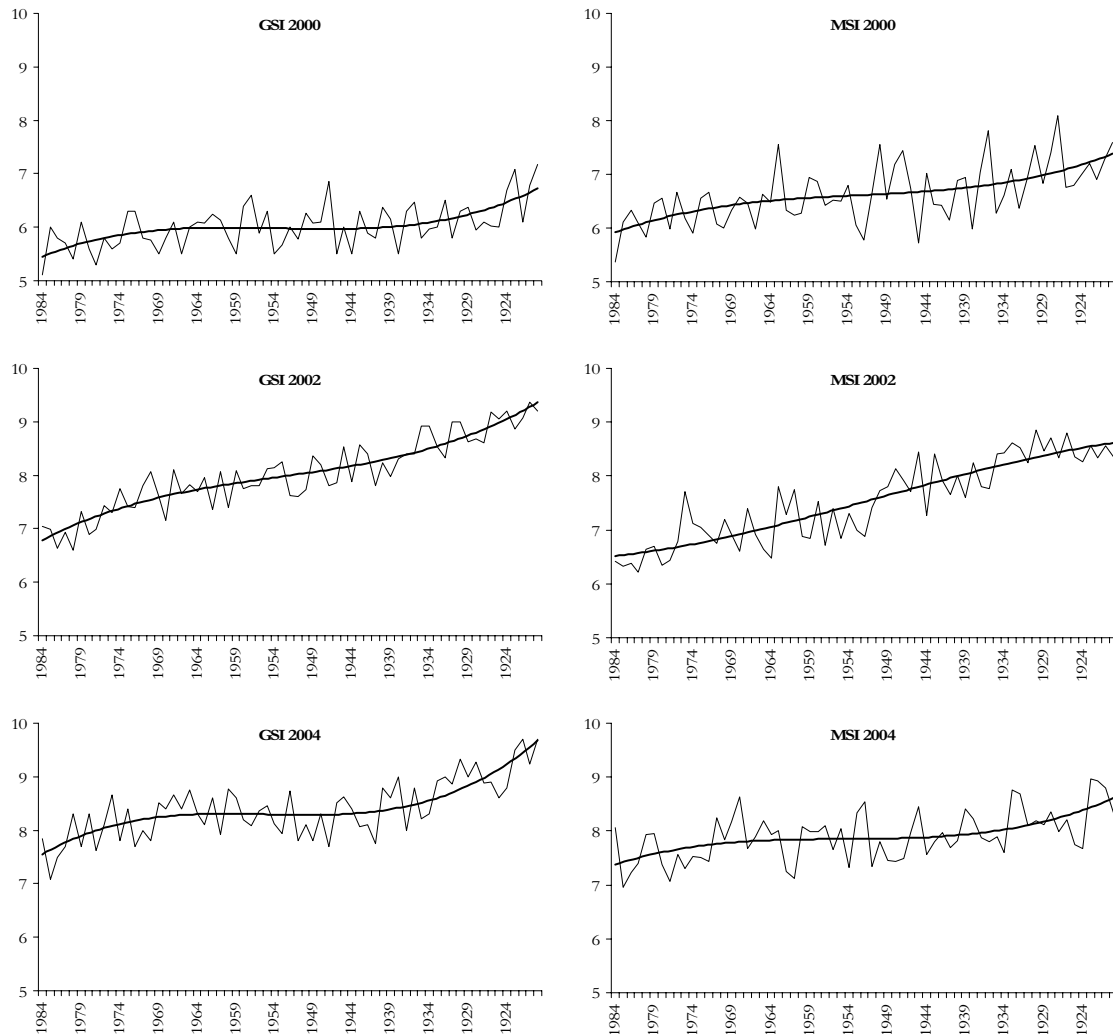

Figure 4 – The profiles of Global Satisfaction Index (GSI) and Mean Satisfaction Index (MSI) over age in 2000, 2002 and 2004.

##### 5. A NEW EXTENDED DYNAMIC VERSION OF LISREL MODEL

In order to evaluate the main factors influencing the TRAM customers overall satisfaction and its dynamic over time, the LISREL approach is used (Jöreskog, 1970). The traditional LISREL model considers random vectors  $\boldsymbol{\eta}' = (\eta_1, \eta_2, \dots, \eta_m)$  and  $\boldsymbol{\xi}' = (\xi_1, \xi_2, \dots, \xi_n)$  of endogenous and exogenous latent variables, respectively, and the following system of linear structural relations

$$\boldsymbol{\eta} = \mathbf{B}\boldsymbol{\eta} + \boldsymbol{\Gamma}\boldsymbol{\xi} + \boldsymbol{\zeta} \quad (1)$$

where  $\mathbf{B}$  and  $\boldsymbol{\Gamma}$  are coefficient matrices of dimensions  $(m \times m)$  and  $(m \times n)$  respectively and  $\boldsymbol{\zeta}' = (\zeta_1, \zeta_2, \dots, \zeta_m)$  is a random vector of residuals. Without loss of generality it may be assumed that  $E(\boldsymbol{\eta}) = 0$ ,  $E(\boldsymbol{\xi}) = 0$ ,  $E(\boldsymbol{\zeta}) = 0$ ,  $\boldsymbol{\zeta}$  is uncorrelated with  $\boldsymbol{\xi}$  and  $\mathbf{B}$  is a not singular matrix.

The vectors  $\eta$  and  $\xi$  are not observed while vectors  $\mathbf{y}' = (y_1, y_2, \dots, y_p)$  and  $\mathbf{x}' = (x_1, x_2, \dots, x_q)$  are observed, such that

$$\mathbf{y} = \Lambda_y \eta + \epsilon \tag{2}$$

$$\mathbf{x} = \Lambda_x \xi + \delta \tag{3}$$

where  $\epsilon$  and  $\delta$  are vectors of measurement errors in  $\mathbf{y}$  and  $\mathbf{x}$ , respectively; both  $\mathbf{y}$  and  $\mathbf{x}$  are assumed to be measured as deviations from their means. The matrices  $\Lambda_y$  and  $\Lambda_x$  are  $(p \times m)$  and  $(q \times n)$  loading matrices of  $\mathbf{y}$  on  $\eta$  and of  $\mathbf{x}$  on  $\xi$ , respectively. It is convenient to refer to  $\mathbf{y}$  and  $\mathbf{x}$  as the observed variables and  $\eta$  and  $\xi$  as the latent variables. The error of measurement are assumed to be uncorrelated with the latent variables.

The *structural-equation part* of the general model, as given in equation (1), specifies the casual relationships among the latent variables; this is used to describe and assess the causal effects and to estimate the amount of unexplained variance in the dependent variables. The *measurement model part* of the general model, as given by equations (2) and (3), specifies how the latent variables are measured in terms of the observed variables; this is used to describe the measurement properties (reliabilities and validities) of the observed variables.

The first extension of the LISREL model to longitudinal studies, where the same or similar quantitative measures have been obtained for several occasion, has been proposed by Jöreskog (1970, 1979 and 2001; *et al.* 1977; and Sörbom, 1977). The Author considers the case of multiwave one variable and introduces dynamics in LISREL model supposing that the latent variable at time  $t$  depends on the same latent variable at time  $(t-1)$ , and that it is measured by the observed variable  $y$  at the same time

$$\eta_i = \beta_i \eta_{i-1} + \zeta_i \quad i = 2, \dots, t \tag{4}$$

$$y_i = \eta_i + \epsilon_i \quad i = 1, 2, \dots, t \tag{5}$$

or, in matrix notation,  $\mathbf{B} \eta_t = \zeta_t$ ,  $\mathbf{y}_t = \eta_t + \epsilon_t$ , where  $\mathbf{B}$  is a coefficient matrix of order  $t \times t$  and  $\eta_t$ ,  $\zeta_t$ ,  $\mathbf{y}_t$  and  $\epsilon_t$  are vectors of dimension  $t$ . The  $\epsilon_i$  are assumed to be uncorrelated among themselves and uncorrelated with  $\eta_i$ ,  $\zeta_{i+1}$  are uncorrelated with  $\eta_i$ .

Jöreskog introduced dynamics in the classic LISREL model only by the latent endogenous variables (Figure 5). This model, called SIMPLEX model, is based on the hypothesis that the latent endogenous variable is generated by an AR(1) process. Generalisations of this model including more observed variables, error correlations and common factors are also considered by Jöreskog (1979), who develops a general model for the analysis of longitudinal data.

Let us suppose that several variables are measured at  $T$  points in time; let  $p_t$  dependent variables be measured at occasion  $t$  and let  $\mathbf{y}'_t = (y_{1t}, y_{2t}, \dots, y_{p_t t})$  be the vector of this  $p_t$  variables. It is assumed, at each occasion, that  $\mathbf{y}_t$  has a common factor structure with  $m_t$  correlated common factors  $\eta'_t = (\eta_{1t}, \eta_{2t}, \dots, \eta_{m_t t})$  so that

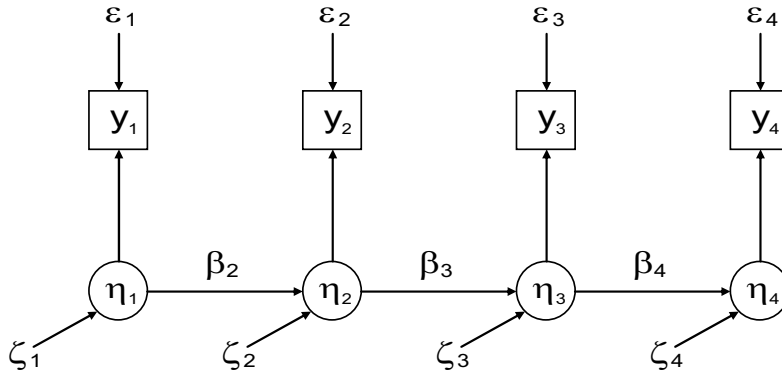

Figure 5 – The SIMPLEX model path diagram.

$$y_t = \Lambda_{yt}\eta_t + \varepsilon_t \tag{6}$$

where  $\varepsilon_t$  is a vector of unique factors and  $\Lambda_{yt}$  is a  $p_t \times m_t$  matrix of factor loadings.

In addition to the dependent variable  $y_t$ ,  $q$  independent variables  $\mathbf{x}' = (x_1, x_2, \dots, x_q)$  representing characteristics and conditions existing before the first occasion are measured and they are supposed to influence the dependent variable  $y_t$  (Figure 6). It is also assumed that  $\mathbf{x}$  has a factor structure with common factors  $\xi' = (\xi_1, \xi_2, \dots, \xi_n)$  so that

$$\mathbf{x} = \Lambda_x \xi + \delta \tag{7}$$

where  $\delta$  is the vector of unique factors and  $\Lambda_x$  is a  $q \times n$  matrix of factor loadings.

The structural equation connecting the  $\eta$ 's and  $\xi$  are assumed to be

$$\eta_1 = \mathbf{A}_1 \xi + \zeta_1 \tag{8}$$

$$\eta_t = \mathbf{A}_t \xi + \mathbf{B}_t \eta_{t-1} + \zeta_t \tag{9}$$

where  $\mathbf{A}_t$  is a regression matrix of order  $m_t \times n$ ,  $\mathbf{B}_t$  is a regression matrix of order  $m_t \times m_{t-1}$  and  $\mathbf{B}_1 = 0$ . The vectors  $\zeta_t' = (\zeta_{1t}, \zeta_{2t}, \dots, \zeta_{m_t t})$  contain the residuals assumed to be correlated within occasions but uncorrelated between occasions.

The SIMPLEX model and its generalisations<sup>2</sup> present some drawbacks. It treats variables at several occasions as distinct variables, therefore the model estimation in presence of more than two occasions does not allow to estimate the data generating process but only the temporal dependence from one occasion to the other one. In presence of more than two time points, the SIMPLEX model is valid only if time-varying coefficient hypothesis is introduced, or if different data generating processes are supposed to influence the dynamics. Thus, we cannot estimate the underlying stochastic process that generated observations at the different times. The problem can be masked by allowing for time-varying AR(1) coefficients.

<sup>2</sup> Alternative extensions of dynamic LISREL Model are discussed in Ferrer and McArdle (2003).

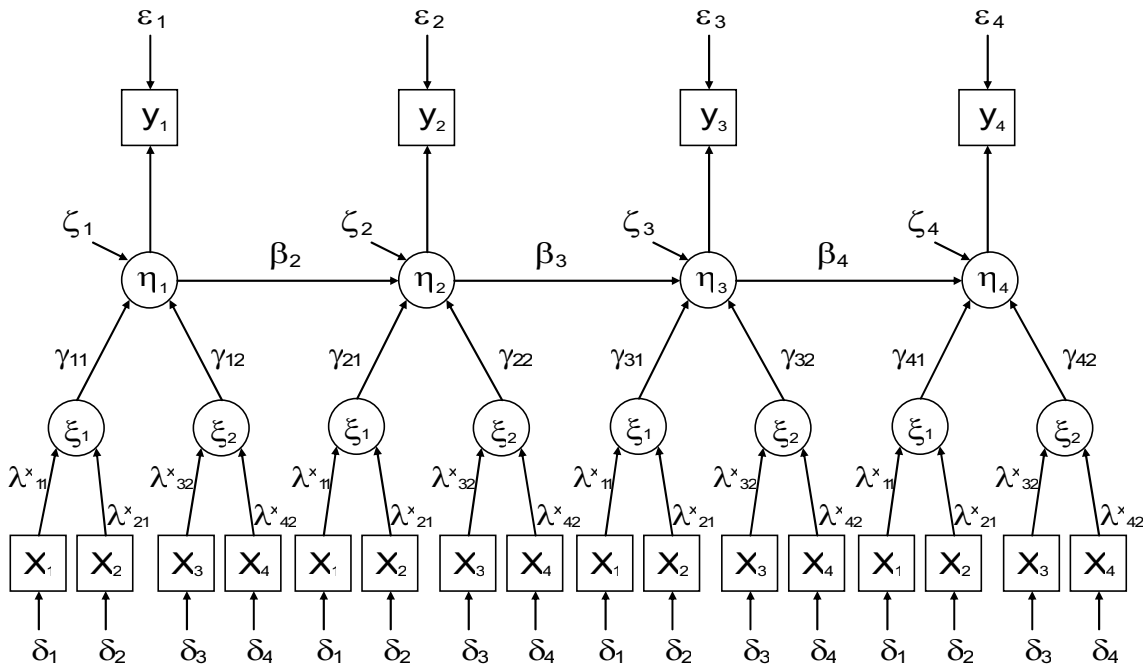

Figure 6 – The GENERAL SIMPLEX model path diagram.

We propose an extension of the SIMPLEX model according to which the latent exogenous variables affect, in the structural model, as in the classic LISREL specification (Figure 7).

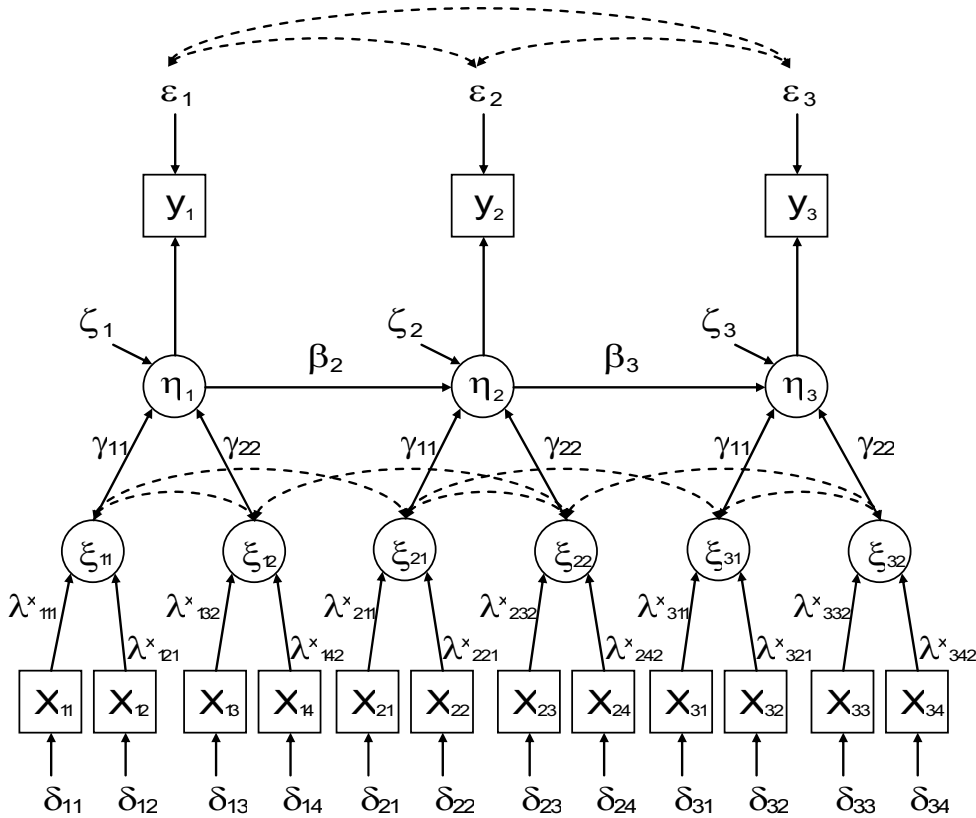

Figure 7 – The EXTENDED SIMPLEX model path diagram.

In our case, the latent endogenous variables,  $\eta$  at time  $t$ , depend on the latent endogenous variables  $\eta$  at time  $t-1$  and on the exogenous latent variables  $\xi$  at the current time  $t$ .

$$\eta_t = \mathbf{B}_t \eta_{t-1} + \mathbf{\Gamma}_t \xi_t + \zeta_t \quad (10)$$

$$\mathbf{y}_t = \mathbf{\Lambda}_{yt} \eta_t + \boldsymbol{\varepsilon}_t \quad (11)$$

$$\mathbf{x}_t = \mathbf{\Lambda}_{xt} \xi_t + \boldsymbol{\delta}_t \quad (12)$$

with  $\eta_1 = \mathbf{\Gamma}_1 \xi_1 + \zeta_1$  ( $\mathbf{B}_1 = \mathbf{0}$ ), being  $\eta_t$ ,  $\xi_t$  vectors of endogenous and exogenous variables, of dimensions  $m_t$  and  $n_t$ ,  $\mathbf{y}_t$  and  $\mathbf{x}_t$  vectors of observable variables, of dimensions  $p_t$  and  $q_t$ ,  $\mathbf{B}_t$  a regression matrix of order  $m_t \times m_{t-1}$ ,  $\mathbf{\Gamma}_1$  a coefficient matrix of order  $m_t \times n_t$ ;  $\mathbf{\Lambda}_{yt}$  and  $\mathbf{\Lambda}_{xt}$  are matrices of factor loadings of dimensions  $p_t \times m_t$  and  $q_t \times n_t$ ,  $\boldsymbol{\varepsilon}_t$  and  $\boldsymbol{\delta}_t$  the corresponding vectors of unique factors. We assume that:  $\boldsymbol{\varepsilon}_t$  are uncorrelated with all  $\eta_t$ ,  $\boldsymbol{\delta}_t$  are uncorrelated among themselves and between occasions and  $\zeta_{t+1}$  is uncorrelated with  $\eta_t$ . In longitudinal studies where the same variables are used repeatedly, there is the tendency for the corresponding errors to correlate over time because of memory and other retest effects. There is a need to generalise the model to allow for correlation between errors: hence we assume that  $\boldsymbol{\varepsilon}_t$  are correlated among themselves and between occasions. We also assume that  $\xi_t$  are correlated among themselves and between occasions. This hypothesis is introduced to take into account the possible interrelation of exogenous latent variables at the same time and the temporal dependence between occasions.

In the following, we verify the proposed EXTENDED SIMPLEX model on the pseudo panel data described in section 4, in the assumption of time-varying AR(1) coefficients even if this is a simplifying hypothesis.

## 6. ESTIMATE RESULTS AND ECONOMIC INTERPRETATION OF THE DYNAMIC MODEL

In order to find the latent structure underlying the TRAM customer satisfaction evaluation system and to specify the structural equation model, we conducted an exploratory factor analysis on the 2004 data, using Principal Axis Factoring and Varimax Rotation. A 3-factor structure, with more than 70% of total variance explained, is the best solution. Accordingly to the items associated to these factors they were named as shown in Table 2. For each of the three sets of items the Cronbach's Alpha was calculated in order to evaluate how well these items measure the latent constructs they refer to. The results, ranging from 0.782 to 0.891, show that all the three sets of items are adequate.

TABLE 2  
Latent factor description

Factor 1 <i>Travel Time</i>	Factor 2 <i>Travel Comfortableness</i>	Factor 3 <i>Customer Relationship</i>
Punctuality	Convenience	Customer Care
Frequency	Cleanliness	Drivers
Speed	Comfort	Environment
	Safety	Handicap
	Bus Shelters	Info
	Tickets Availability	Ticket Price
Cronbach's Alpha: 0.810	Cronbach's Alpha: 0.891	Cronbach's Alpha: 0.782

The confirmatory analysis indicates that the measurement model defined for 2004 has a good fit as indicated by a chi-square of 106.38 with 63 degrees of freedom ( $\chi^2/df=1.69$ ) and Adjusted Goodness of Fit Index of 0.92. The same measurement model applied to data referred to 2000 ( $\chi^2/df=1.76$ , AGFI=0.88) and 2002 ( $\chi^2/df=1.74$ , AGFI=0.89) shows a good fit.

A structural equation model with the aim to verify the hypotheses previously defined is specified. Because of the reduced number of available observations with respect to the high number of parameters to estimate, we specified a parsimonious model in which only the first two factors were included. Dynamics was introduced in the structural model through time (causal) dependence between overall satisfaction latent variables. In Figure 8 the model referred to a single year is represented: the two latent exogenous variables, "Travel Time" and "Travel Comfortableness", measured by the items reported in Table 2, affect the latent endogenous variable "Overall Satisfaction" that is measured by the observed variables "Global Judgment" and "Expectations". The EXTENDED SIMPLEX model introduces the further assumption that the "Overall Satisfaction" at the current time depends on the "Overall Satisfaction" of the previous time, and affects the Overall Satisfaction of the following time, as indicated by the hatched arrows.

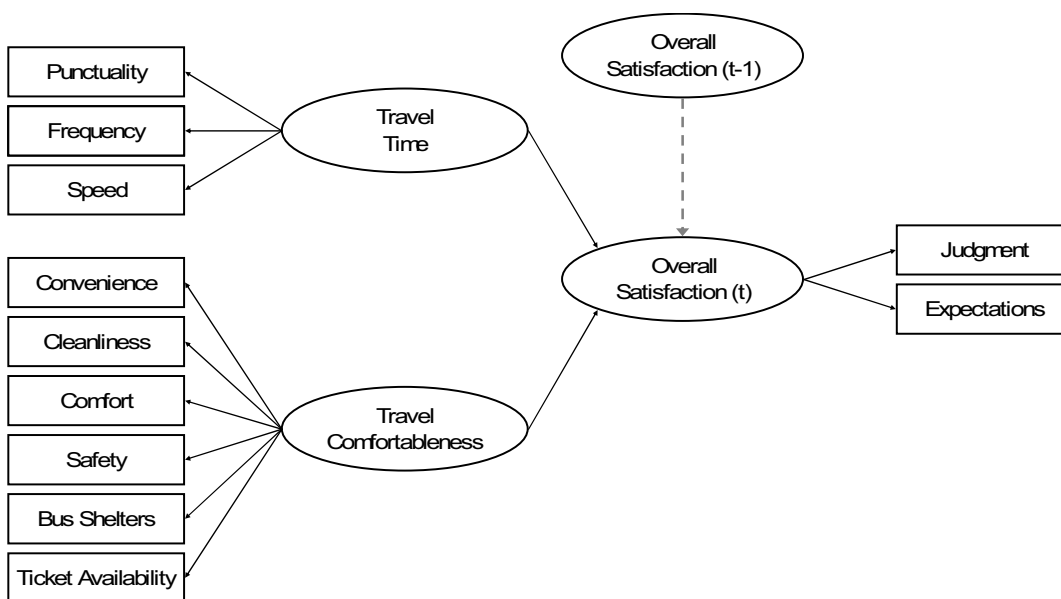

Figure 8 – The path diagram at time t.

The specified model is estimated with the Weighted Least Squares (WLS) method and all the parameters have positive sign with high  $t$  values (Table 3). The model has a good fit as indicated by Normed Fit Index (NFI)=0.97, Non-Normed Fit Index (NNFI)=0.98, Comparative Fit Index (CFI)=0.98, Incremental Fit Index (IFI)=0.98, Relative Fit Index (RFI)=0.97 and AGFI=0.97. The Root Mean square Residual (RMR) of 0.27 and the Root Mean Square Error of Approximation of 0.201 are not really good but this is not surprising whit such a parsimonious model has indicated by the Parsimony Normed Fit Index (PNFI)=0.92 and Parsimony Goodness of Fit Index (PGFI)=0.87 (Browne and Cudeck, 1993).

TABLE 3  
*Structural model coefficients estimates (t values in brackets)*

	$\eta_1$	$\eta_2$	$\eta_3$
Travel Time 2000 ( $\xi_{11}$ )	0.13 (3.85)		
Travel Comfortableness 2000 ( $\xi_{12}$ )	0.08 (2.99)		
Travel Time 2002 ( $\xi_{21}$ )		0.81 (15.89)	
Travel Comfortableness 2002 ( $\xi_{22}$ )		0.11 (3.64)	
Travel Time 2004 ( $\xi_{31}$ )			0.49 (7.52)
Travel Comfortableness 2004 ( $\xi_{32}$ )			0.99 (10.23)
Overall Satisfaction 2000 ( $\eta_1$ )		0.11 (3.81)	
Overall Satisfaction 2002 ( $\eta_2$ )			0.09 (2.89)

Model estimate showed some interesting results in order to verify our hypotheses and evaluate customers satisfaction dynamics (Figure 9)<sup>3</sup>.

The estimates of the model on cohort data give significant results and therefore support the assumption that public transport evaluations change over customer age. However, the present version of the EXTENDED SIMPLEX model doesn't allows to obtain parameter estimate of age effects on overall satisfaction, that can be evaluated introducing additional covariates in the model: this is the object of our future research.

Secondly, "Overall satisfaction" depends, in all the three years, both on "Travel Time" and on "Travel Comfortableness". Coefficients with positive sign indicate that higher levels in Travel Time Satisfaction and, similarly, in Travel Comfortableness Satisfaction lead to higher level in Overall Satisfaction (see Hypotheses H.1 and H.2). The Hypotheses H.5.2 is also supported by the data: the role of the two factors changes over time. The influence of "Travel Comfortableness" increases over time (0.08, 0.11 and 0.99 respectively), while "Travel Time", starting from 0.13 in 2000 increases in 2002 (0.81), but reduces in 2004 (0.49).

<sup>3</sup> In Figure 9, not significant  $\text{Var}(\delta_i)$  are imposed to be zero. The model estimate evidences an Heywood case on  $\text{Var}(\epsilon_{1,1})$  and  $\text{Var}(\epsilon_{3,2})$ : they may not be identified and therefore are imposed to be zero (Bartholomew *et al.*, 2002), (gray labels and arrows).



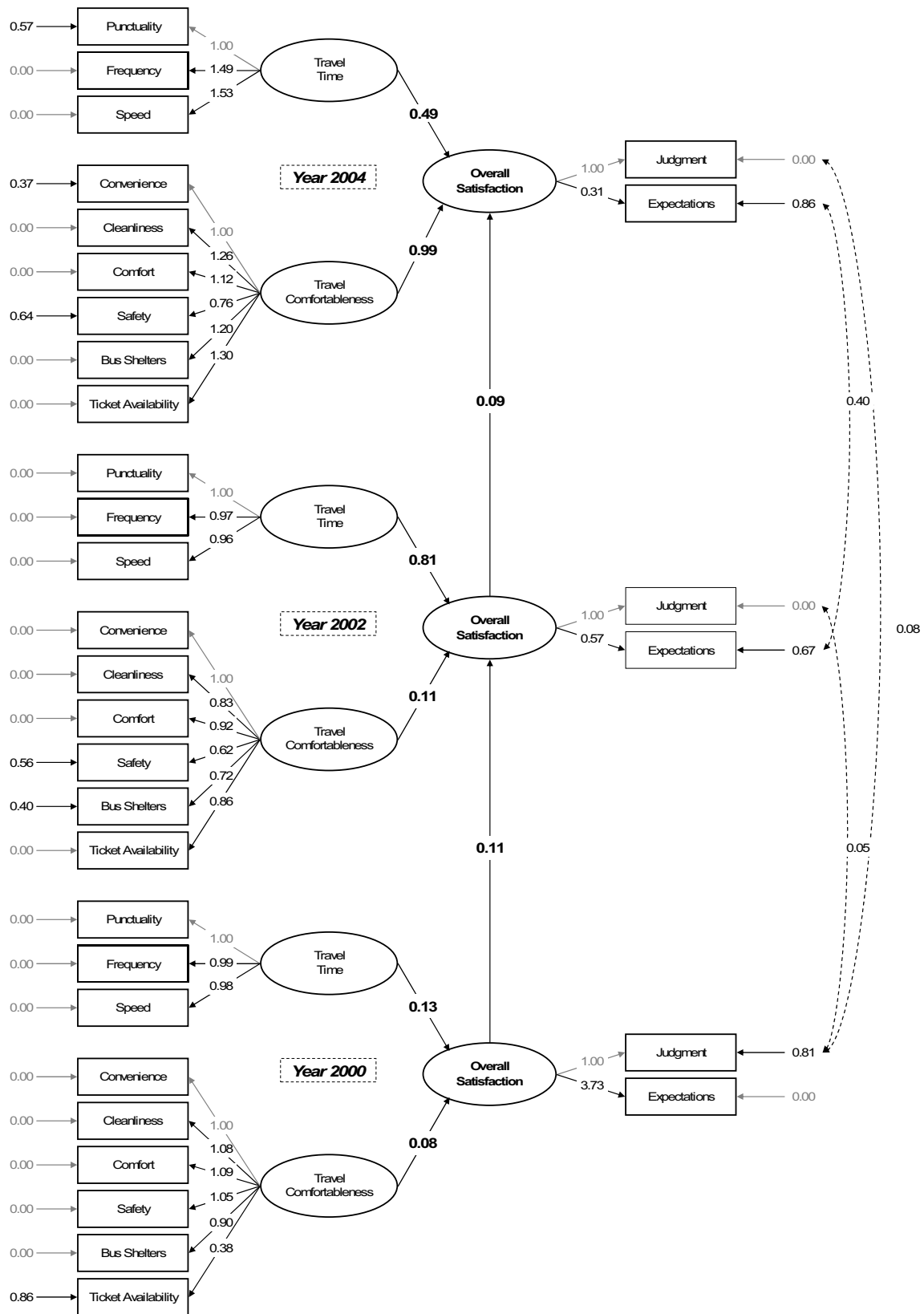

Figure 9 – Model estimates.

Therefore the results show that customers conditions on the bus and the easiness of the public transport use increases over time: this is a relevant factor af-

fecting the customer satisfaction and its relevance increases over time. In addition, parameters that show how much “Overall Satisfaction” at one time affects the corresponding satisfaction of the following year, are significantly different from zero, confirming the presence of dynamics in the customer satisfaction evaluations (Hypotheses H.5.1).

Expectations are hypothesized to have an impact on satisfaction (Hypotheses H4). Indeed, there is ample evidence to indicate that the role of Expectations in measuring the “Overall Satisfaction” is positive but decreases over time and this is a very interesting finding for a phenomenal point of view. This means that customers improve public transport service knowledge by using it; therefore what they get is not so different from what they expect to have. In other words, the use of public transport is largely habitual as the most travel mode choices.

## 7. CONCLUSIONS AND FUTURE RESEARCHES

This study develops a dynamic customer satisfaction model for the urban transport customers with the aim to investigate if customer satisfaction changes over time and which are the main determinants of the customer satisfaction. The conceptual model used in the analysis relates the customer Overall Satisfaction to customer evaluations about Travel Time and Travel Comfortableness and it highlights how these relations change over time.

In absence of panel data on customer evaluation of the public transport service we propose to use the average cohort technique to generate pseudo panel data. Because of the quality evaluation changes over customer age, the average cohort technique can be usefully used to explore the dynamics in the quality evaluation of the public transport. Therefore pseudo panel data solves the typical problem of the lack of longitudinal observation on customers and allows dynamic analysis by LISREL Model.

In the paper we also propose a new extended version of the traditional SIMPLEX model introducing the latent exogenous variable effects in the structural model: in our model latent endogenous variables at time  $t$  depend on the latent endogenous variables at the previous time and on the exogenous latent variables at the current time.

Structural model estimate and tests indicate that the customer satisfaction changes over age and over time and that it is influenced by some characteristics of the transport service, such as the time and the comfortableness of the travel. Expectation also affects the overall satisfaction but its influence decreases in time supporting the hypothesis that the public transport mode choice is habitual.

EXTENDED SIMPLEX model on pseudo panel data is an interesting framework to analyze customer satisfaction and it provides interesting results. Unfortunately it is weak for dynamic analysis because it is derived under the assumption of time varying coefficients. Further researches will be conducted to overcome this hypothesis and to test dynamic model in the Observed Form Solution as proposed by Bollen (1996, 2001) In particular, our future efforts will be concen-

trated in estimating the LISREL model using pseudo panel data in the long format. This solution allows for autoregressive distributed lag structural equation models (ADL) with latent variables, thus overcoming the problem of time varying coefficients.

*Dipartimento di Scienze Statistiche  
Università di Bologna*

CRISTINA BERNINI  
ALESSANDRO LUBISCO

## REFERENCES

- BAGOZZI R.P., WARSHAW P.R. (1990). *Trying to consume*. Journal of Consumer Research, vol. 17, 127-140.
- BAGOZZI R.P. (1994). Structural Equation Models in Marketing research: basic principles. In Bagozzi R.P., Principles of marketing Research, Cambridge, Blackwell, 317-385.
- BARTHOLOMEW D.J., STEELE F., MOUSTAKI I., GALBRAITH J.I. (2002). *The analysis and interpretation of multivariate data for social scientists*. Chapman and Hall, London.
- BOLLEN K.A. (1996). *An alternative Two Stage Least Squares (2SLS) estimator for latent variables equations*. Psychometrika, vol. 61, n. 1, 109-121.
- BOLLEN K.A. (2001). *Two Stage Least Squares and latent variables models: simultaneous estimation and robustness to misspecifications*. In R.Cudeck, S. Du Toit and D. Sorböm (eds) Structural equations modelling: present and future, a festschrift in honor of Karl Jöreskog. Lincoln, IL: Scientific Software, 119-138.
- M. BROWING, A. DEATON, M. IRISH (1985), *A profitable approach to labor supply and commodity demands over the life-cycle*. "Econometria", vol. 53, pp. 503-544.
- BROWNE M., W CUDECK R. (1993). In Alternative ways of assigning model fit. In Bollen K. A. Scott Long J. Testing structural equation models, Sage Publications, Newbury Park, 136-162.
- CAGNONE S., LUBISCO A., MIGNANI S. (2003), *Modelli a variabili latenti per l'analisi della Customer Satisfaction degli utenti dei servizi di trasporto pubblico*, collana Appunti e ricerche n. 2, Alma Mater Studiorum Università di Bologna Polo scientifico didattico di Rimini.
- DEATON A. (1985), *Panel data from time series of cross-section*. "Journal of Econometrics", vol. 30, pp. 109-126.
- FERRER E., MCARDLE J.J. (2003), *Alternative Structural Model for multivariate longitudinal data analysis*. Structural Equation Modeling, vol. 10, n. 4, 493-524.
- FUJII S., GÄRLING T., KITAMURA R. (2001), *Changes in drivers' perceptions and use of public transport during a freeway closure: effects of temporary structural changes on cooperation in a real life social dilemma*. Environment and behaviour, vol. 33, n. 6, 796-808.
- GÄRLING T., BOE O., FUJII S. (2001), *Empirical tests of a model of determinants of script based driving choice*. Transportation research F, vol. 4, 89-102.
- GOLOB T.F. (2003), *Structural equation modelling for travel research*. "Transportation research Part B: Methodological", vol. 37, pp. 1-25.
- JAKOBSSON C., FUJII S., GÄRLING T. (2002), *Effects of economic disincentives on private car use*, Transportation, vol.29, n.4, pp. 349-370.
- JÖRESKOG K.G. (1970), *Estimation and testing of simplex models*. "British Journal of Mathematical and Statistical Psychology", vol. 23, pp. 121-145.
- JÖRESKOG K.G. ROCK D.A. WERTS C.E. and LINN R.L. (1977), *A maximum likelihood solution to the errors in variables and errors in equation models*. Journal of Multivariate Behavioral Research, vol. 12, 187-197.

- JÖRESKOG K.G., SÖRBOM D. (1977), *Statistical models and methods for analysis of longitudinal data*. In D.J. Aigner and A.S. Goldberger (Eds.): *Latent Variables in Socioeconomic Models*. Amsterdam: North-Holland Publishing Co.
- JÖRESKOG K.G. (1979), *Statistical estimation of Structural Model in longitudinal-developmental investigation*. In "Longitudinal research in the study of behaviour and development" (Edited by J. R. Nesselroade), pp. 303-352.
- JÖRESKOG K.G. (2001). *Analysis of Ordinal Variables: Longitudinal Data*. In "Scientific Software International".
- PETER J.P., OLSON J.C., GRUNERT K.G. (1999), *Consumer behaviour and marketing strategies*. London, McGraw Hill.
- THÖGERSEN J. (2001), *Structural and psychological determinants of the use of public transport*. Presented at the TRIP colloquium at Horsholm (14-15 november).
- STEENKAMP J.B., BAUMGARTNER H. (2000), *On the use of structural equation models for marketing modeling*. International Journal of Research in Marketing, vol. 17, pp. 195-202.
- ZANELLA A. (2001), *Valutazione e modelli interpretative di Customer satisfaction: ricerca di un quadro complessivo*. In "Processi e Metodi statistici di Valutazione", Atti del Convegno Intermedio SIS, pp. 113-120.

#### RIASSUNTO

*Una nuova versione dinamica del modello Simplex per l'analisi della Customer Satisfaction nei servizi di trasporto pubblico*

L'analisi dinamica della Customer Satisfaction risulta particolarmente utile per monitorare la soddisfazione dei clienti nel tempo e per verificare l'effetto delle strategie aziendali sui comportamenti dei clienti. Tale analisi consente alle aziende di misurare l'efficacia e l'efficienza delle proprie politiche. In particolare, gli obiettivi del lavoro sono di verificare se la soddisfazione cambia nel tempo e se le aspettative dei clienti influenzano la soddisfazione globale, e di individuare quali sono i fattori che in misura maggiore hanno determinato la dinamica della soddisfazione. A questo scopo, viene proposta una versione originale del modello LISREL in contesto dinamico. La verifica empirica del modello è stata condotta su dati pseudo-panel, costruiti a partire dall'indagine sulla Customer Satisfaction dei servizi pubblici di trasporto dell'Agenzia Tram di Rimini, realizzata dalla Facoltà di Scienze Statistiche negli anni 2000-2004.

#### SUMMARY

*A new extension of dynamic simplex model for the public transport customer satisfaction*

The dynamic analysis of Customer Satisfaction is particularly useful for monitoring either customer satisfaction over time or customer behaviour reaction to company strategies, and therefore for measuring their effectiveness and efficiency. In the paper we address the following questions: does the level of customer satisfaction change over time? If yes, which factors might explain these differences? Does customer expectation influence the overall satisfaction over time? In order to answer to these questions, we propose a new extended dynamic version of LISREL model and we evaluate its performance on pseudo-panel data, built on the Customer Satisfaction of Tram Surveys conducted by the Faculty of Statistical Sciences for the Tram Agency of public transport in Rimini in the period 2000 to 2004.